

# 承 認 書

## Specification for Approval

Edition	A0
No.	

客戶 Customer:			
客戶料號 Customer Part NO.:			
產品名稱 Product Name.:	TACT SWITCH		
產品型號 Part NO.:	TS02.036B.S3B70		
客戶簽署 Customer Sign:	長風簽署 Supplier Sign		
	製作 Prepared by	審覈 Checked by	批准 Approved by
客戶蓋章 Customer Seal	長風蓋章 Supplier Seal		
承認日期 Accept Date: _____	製作日期 Prepare Date: _____		

地址：浙江省樂清市虹橋鎮幸福東路 580 號

Add: NO.580, Xingfu East Road, Hongqiao, Yueqing, Zhejiang, China.

Http://www.cfswitch.com

E-mail:manager@cfswitch.com

郵編//ZIP: 325608

Tel: 0577--62351939 62361939

Fax: 0577--62355959

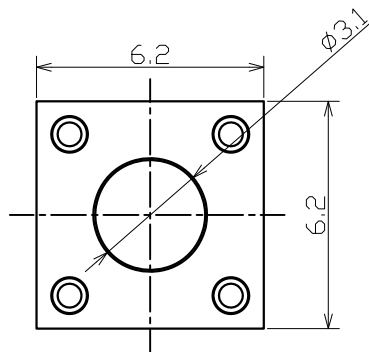
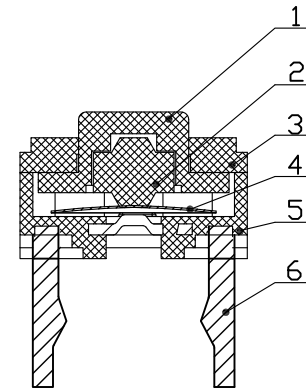
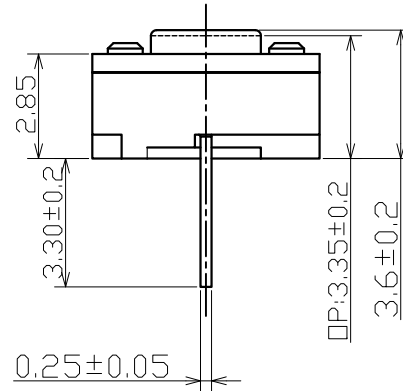
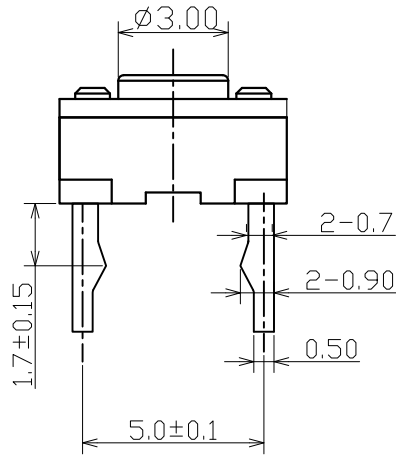

ITEM	PART NAME	MATERIAL	COLOR
1	BUTTON	POM	BLACK
2	SILICA GEL	SILICA GEL	
3	COVER	PBT	BLACK
4	SPRING	SUS	
5	BASE	PA66	BLACK
6	TERMINAL	SILVER PLATE BRASS	

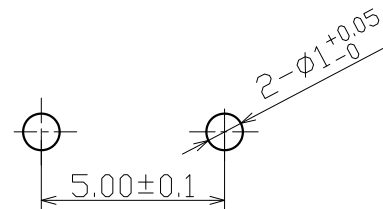

(Tolerance:  $\pm 0.1$ )  
(P.C.B thickness  $t=1.6$ )



Rating	6VDC 50mA
Contact Resistance	500m $\Omega$ Max
Insulation Resistance	50M $\Omega$ Min
Dielectric Voltage	250VAC 60 $\pm$ 5S
Endurance	3,000,000 cycles
Operating Force	70 $\pm$ 15gf
Pre-travel	0.25 $\pm$ 0.15mm

MARK.	REV.	REVISION NOTE	DATE	UNIT	mm	TOLERANCE	SCALE	1:1	 浙江長風電子有限公司 Zhejiang Changfeng Electronics Co., Ltd.		
				DRAWN		x. $\pm 0.5$ ANGLES	SHEET	1/1			
				CHECKED		.x $\pm 0.3$ x. $^{\circ}$ $\pm 2^{\circ}$	REV.	A0		TITLE	TACT SWITCH
				APPROVED		.xx $\pm 0.1$ .x. $^{\circ}$ $\pm 1^{\circ}$	PROJ.			MODEL	TS02.036B.S3B70



產品名稱: Product Name	TACT SWITCH	產品型號: Part NO.	TS02.036B.S3B70	文件版本: Edition	A0
-----------------------	-------------	-------------------	-----------------	------------------	----

**1. General Characteristics 一般特性:**

- 1.1 額定值: 6VDC 50mA  
Rating Value: 6VDC 50mA
- 1.2 工作溫度: -25°C ~ 70°C  
Work Temperature Range : -25°C ~ 70°C
- 1.3 存貯溫度: -25°C ~ 70°C  
Store Temperature Range): -25°C ~ 70°C
- 1.4 正常測試條件 (未有特殊說明量測在以下條件進行):  
General test condition (Test and measurements shall be made under the following standard conditions unless otherwise specified):  
 正常溫度: 5°C ~ 40°C      相對濕度: ≤85%(40°C )      氣 壓: 102kpa ~ 103kpa  
 Temperature: 5°C ~ 40°C      Relative humidity: ≤85%(40°C )      Air pressure: 102kpa ~ 103kpa

**2. Appearance, Structure and Dimensions 外觀, 結構及尺寸:**

- 2.1 Appearance:                      The switch shall have qualified, and no rusts, cracks or plating defects.  
外觀:                                      產品外觀合格, 無銹蝕、裂紋和鍍層缺陷。
- 2.2 Structure & Dimensions:      Refer to individual product drawing.  
結構及尺寸:                              參見產品圖紙。
- 2.3 Markings:                         Refer to individual product drawing.  
標識:                                        參見產品圖紙。

**3. Electrical Characteristics 電氣性能**

No.	項目 Item	實驗方法 Test Method	測試設備 Equipment	特殊要求 Requirements
3.1	接觸電阻 Contact Resistance	Any equipment with error not more than 5% can be used. Resistance after test is the average of 5 successive measurements. 用誤差不超過 5% 的儀錶進行測試, 實驗後的電阻取 5 次測量的平均值。	低電阻測試儀 Low Resistance Tester	500mΩ Max.
3.2	絕緣阻抗 Insulation Resistance	250VDC voltage is applied between each pair of terminals and between the terminal and the metal frame for 60±5S. 在相互絕緣的所有端子之間及各接線端子與外露的非載流金屬零件之間加載 250V 直流電, 持續時間 60±5S。	絕緣測試機 Insulation Resistance Tester	50MΩ Min.
3.3	耐壓測試 Dielectric Withstand Voltage	250VAC (50~60Hz, cut-off current 2mA) is applied between non-connected terminals and between terminals and the metal frame for 60 ±5s. 在相互絕緣的所有接線端子之間 250V (50-60Hz) 交流電, 各接線端子與外殼或非載流金屬零件之間加載 250V (50-60Hz) 交流電, 持續時間 60±5S。	耐壓測試機 Puncture Tester	無電弧、擊穿現象發生。 No arcing, break-down shall occur.

產品名稱: Product Name	TACT SWITCH	產品型號: Part NO.	TS02.036B.S3B70	文件版本: Edition	A0
-----------------------	-------------	-------------------	-----------------	------------------	----

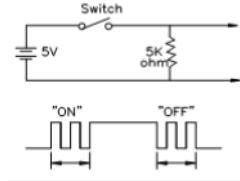
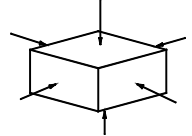
4. Mechanical Characteristics 機械特性					
No.	項目 Item	實驗方法 Test Method	測試設備 Equipment	特殊要求 Requirements	
4.1	操作力 Operation Force	垂直操作開關按鍵，逐漸施力，測量開關到達全部工作行程時所需的最大操作力度。 Operate the keystroke of the switch vertically, and then increase press strength gradually, Measured maxi-mum operation force to be need while the travel of switch is full.	推拉力計 Push-Pull Force Gauge	參照圖紙 See drawing	
4.2	行程 Pre-travel	垂直操作開關按鍵，測量開關頂端導通時的移動距離。 Operate the keystroke of the switch vertically, the travel distance of keystroke moving from its free position to operation position shall be measurement.	PT 治具 遊標卡尺 PT Tester Calipers	參照圖紙 See drawing	
4.3	跳動 Bounce Time	以 3-4 次/秒的速率按壓開關，測試開關“開”和“關”之間的跳動時間。 Lightly striking the center of the button at a rate encountered in normal use (3 or 4 operations per sec.) bounce shall be test at “ON” and “OFF” .	示波器 Oscilloscope 	5ms Max	
4.4	端子強度 Load Strength of Terminal	于開關端子任意方向施加 0.5Kg 的力，持續時間 1 分鐘。 Apply 0.5Kg load to terminals of the switch in any direction for 1 minute.	砝碼 Poise	端子無脫落、斷裂、鬆動，無功能性不良。 Terminals shall not be broken off, rupture, looseness. No functional defective occur.	
4.5	Mechanical Shock 衝擊	試件在下述參數條件下進行試驗： (1) 安裝方法：常規方法 (2) 加速度：490m/ s <sup>2</sup> (50G) (3) 時間：11ms (4) 實驗方向：力求 6 方向  (5) 衝擊次數：每個方向 3 次（總共 18 次） Switch shall be measured after following test: (1) Mounting Method: Normal (2) Acceleration: 490m/s <sup>2</sup> (50G) (3) Duration: 11ms (4) Test Direction: 6 directions (5) Number of shocks: 3 times per direction (18 times in total)	衝擊測試儀 Shocking Tester	外觀、結構無損傷，功能無異常。 Appearance, construction and function shall be satisfied.	

產品名稱: Product Name	TACT SWITCH	產品型號: Part NO.	TS02.036B.S3B70	文件版本: Edition	A0
-----------------------	-------------	-------------------	-----------------	------------------	----

**5. Reliability Characteristics 可靠性性能**

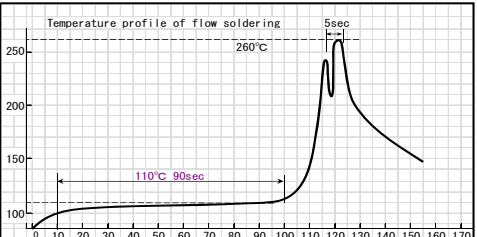
No.	項目 Item	實驗方法 Test Method	測試設備 Equipment	特殊要求 Requirements
5.1	可焊性測試 Solder ability Test	<p>在使用助焊劑的條件下，將端子頂部浸入焊爐中 2mm 深，溫度為 260°C ± 5°C，時間 3 ± 1s（焊劑為質量百分比為 25%松香，75%甲醇的無色透明溶液）。</p> <p>The top of the terminals shall be dipped 2mm in the solder bath at 260°C ± 5°C for 3 ± 1 seconds. This process need use flux (Rosin Flux having a nominal composition of 25% solids by mass of water white rosin in methyl alcohol solution) .</p>	控溫錫爐、 自動焊接機 Solder Stove Auto-Dip Chamber	引腳沾錫面積>80%。 Eighty percent of terminals shall be dipped.
5.2	耐焊接熱試驗 Resistance to Soldering-heat Test	<p>試件按下述試驗條件進行試驗：</p> <p>(1)無鉛焊接溫度及時間： 波峰焊：260°C Max, 5s Max.; 烙鐵焊：350°C Max 2-3s</p> <p>(2)焊料：Sn-3.0 Ag-0.5 Cu /無鉛錫</p> <p>(3)焊劑：焊劑，質量百分比為 25%松香，75%甲醇的無色透明溶液。</p> <p>(4)深漬速度：25(±6) mm/s (1.00±0.25in.)</p> <p>(5)浸漬深度：在安裝基準面的 1~1.5mm 以內</p> <p>(6)試件按下述實驗條件過一次波峰焊。</p>  <p>Switch shall be tested according to the following request:</p> <p>(1) Soldering Temperature &amp; Immersing Time(tin/lead-free): Wave soldering: 260°C Max 5s Max Manual soldering: 350°C Max 2-3s</p> <p>(2) Solder: Sn-3.0 Ag-0.5 Cu tin/lead-free.</p> <p>(3) Flux: Rosin Flux having a nominal composition of 25% solids by mass of water white rosin in methyl alcohol solution.</p> <p>(4) rate of immersion and emergence: 25(±6)mm(1.00±0.25in.), per second</p> <p>(5) Immersion Depth: The required depth of immersion is to within 1~1.5mm of the device body.</p> <p>(6) The product should go through wave soldering for 1 times based on the following test condition.</p>	烙鐵 自動焊接機 Soldering Iron Auto-Dip Chamber	外觀、結構無損傷，功能無異常。 Appearance, construction and function shall be satisfied.

產品名稱: Product Name	TACT SWITCH	產品型號: Part NO.	TS02.036B.S3B70	文件版本: Edition	A0
-----------------------	-------------	-------------------	-----------------	------------------	----

No.	項目 Item	實驗方法 Test Method	測試設備 Equipment	特殊要求 Requirements
5.3	機構壽命測試 Mechanical Life Test	在不帶負荷的條件下，速度為 120~180 次/分，在壽命試驗設備上連續轉換 3,000,000 次。 3,000,000 cycles of operation shall be performed continuously at a rate of 120 to 180 cycles per minute without load.	機械壽命試驗機 Mechanical Life Tester	接觸電阻: 5Ω Max. 絕緣電阻: 10MΩ Min. 操作力衰變應在±30%以內。 其它電氣和機械性能無異常 Contact resistance: 5Ω Max. Insulation resistance: 10MΩ Min. Tolerance of operating force Disintegration shall be within 30% of specified value Electrically and mechanically performances shall be satisfied.
5.4	電氣壽命測試 Electronics Life Test	在帶以下負荷的條件下，速度為 120~180 次/分，在壽命試驗設備上連續轉換 3,000,000 次。DC6V 50mA 3,000,000 cycles of operation shall be performed continuously at a rate of 120 to 180 cycles per minute with load as follow DC6V 50mA	電氣壽命試驗機 Electronics Life Tester	接觸電阻: 5Ω Max. 絕緣電阻: 10MΩ Min. 操作力衰變應在±30%以內。 其它電氣和機械性能無異常 Contact resistance: 5Ω Max. Insulation resistance: 10MΩ Min. Tolerance of operating force Disintegration shall be within 30% of specified value Electrically and mechanically performances shall be satisfied.
5.5	耐高溫測試 Resistance to Heat Test	放置在溫度 70±2℃環境中 48 小時後，再置于正常條件 1 小時後測試。 The switch shall be stored at a temperature of 70±2℃ for 48 hours, Measurements shall be made after it be subjected to the standard conditions for 1 hour.	高低溫箱 High-low Temperature Test Chamber	外觀、結構無損傷，功能無異常。 Appearance, construction and function shall be satisfied.
5.6	耐低溫測試 Resistance to Cold Test	放置在溫度-25±3℃環境中 48 小時後，再置于正常條件下 1 小時後測試。 The switch shall be stored at a temperature of -25±3℃ for 48 hour, Measurements shall be made after it be subjected to the standard conditions for 1 hour.	高低溫箱 High-low Temperature Test Chamber	外觀、結構無損傷，功能無異常。 Appearance, construction and function shall be satisfied.

產品名稱: Product Name	TACT SWITCH	產品型號: Part NO.	TS02.036B.S3B70	文件版本: Edition	A0
-----------------------	-------------	-------------------	-----------------	------------------	----

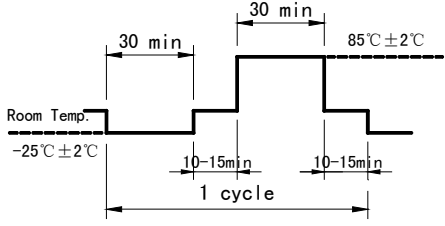
No.	項目 Item	實驗方法 Test Method	測試設備 Equipment	特殊要求 Requirements
5.7	恒定濕熱 Steady state damp heat test	<p>放置于溫度 <math>40 \pm 2^{\circ}\text{C}</math>，相對濕度為 90~95% 環境中 48 小時後，再置于正常條件下 1 小時後測定（注意要擦去水滴）。</p> <p>The switch shall be stored at a temperature of <math>40 \pm 2^{\circ}\text{C}</math>, relative humidity 90 ~ 95 % for 48 hours. Measurements shall be made after it be conditions for 1 hour (Wipe out water drip).</p>	<p>恒溫恒濕箱 Temperature &amp; Humidity Chamber</p> <p>&amp; Tester</p>	<p>外觀、結構無損傷，功能無異常。</p> <p>Appearance, construction and function shall be satisfied.</p>
5.8	溫度轉換 Temperature Cycling	<p>試件按下述實驗條件試驗 5 次，然後在正常溫度和濕度下恢復 1 小時，並在以後 1 小時內對試樣進行測量。</p> <p>After 5 cycles of following conditions, the Switch shall be allowed to stand under normal temperature and humidity conditions for 1 hour, and measurement shall be made within 1 hour after that. Water drops shall be eliminated.</p> 	<p>高低溫箱 High-low Temperature Test Chamber</p>	<p>外觀、結構無損傷，功能無異常。</p> <p>Appearance, construction and function shall be satisfied.</p>
5.9	鹽霧試驗 Salt Mist	<p>在 <math>35 \pm 2^{\circ}\text{C}</math>，鹽溶液濃度為 <math>5 \pm 1\%</math>（質量百分比）的條件下進行噴霧試驗 8 小時，試驗後將鹽沈澱物用水沖除後再測試。</p> <p>The switch shall be done spraying experiment based on <math>35 \pm 2^{\circ}\text{C}</math>, <math>5 \pm 1\%</math> salt solution (solids by mass) for 8 hours. Measurements shall be made after salt deposit shall be cleaned by water.</p>	<p>鹽霧測試機 Salt Mist Tester</p>	<p>外觀、結構無損傷，功能無異常。</p> <p>Appearance, construction and function shall be satisfied.</p>



產品名稱: Product Name	TACT SWITCH	產品型號: Part NO.	TS02.036B.S3B70	文件版本: Edition	A0
-----------------------	-------------	-------------------	-----------------	------------------	----

**6.Precautions for use 注意事項:**

6.1 為防止本產品的性能劣化和耐焊性等性能受到影響，請保管在以下的條件和環境下：

In order to protect the switch performance and the soldering conditions, it should keep the switch under the following conditions:

6.1.1. 溫度 -25℃ 以上，+70℃ 以下，濕度85% 以下的環境。

Temperature of -25℃ to +70℃, with humidity lower than 85%RH;

6.1.2. 避免保存在含有腐蝕性氣體等的空氣中。

Avoid storing in the environment containing corrosive gas;

6.1.3. 避免保存在日光能直射的場所。

Avoid keeping it in the location with direct sunlight.

6.1.4. 在不施加負重外力的包裝狀態下進行保管。

Store using the standard packing without exerting force.

6.2 產品未打開包裝的保存標準期限為6個月。打開包裝後有剩餘品時，應將剩餘部分以膠袋包裝好以同外界隔離，請進行合適的防濕，防腐蝕氣體等處理後進行保管，保存期限為3個月。

The standard storage period is 6 months before opening the package. Preferably to be used as soon as possible. After opening the package, you should put the remaining switches in a plastic bag to prevent from damp and corrosive gas with maximum up to 3 months.

若沒有特殊要求，試驗標準中的“外觀、結構無損傷，功能無異常。”是指要求滿足以下條件

Unless otherwise specified, The meaning of appearance, construction and function shall be satisfied the following conditions in test standard:

接觸電阻 Contact Resistance	1Ω Max.
絕緣電阻 Insulation Resistance	50MΩ Min.
耐壓測試 Dielectric Withstand Voltage	100V AC for 1 minute Min. No dielectric breakdown. 100V AC 1 分钟, 无击穿现象发生。
操作力 Operating Force	70±15gf
其它 Other	The switch shall be free from abnormalities in appearance. 開關的外觀應無明顯損壞。