

1. Material list

ITEM	DESCRIPTION	MATERIAL
1	Cover	SUS301
2	Anchor Plate	SUS301
3	Wheel gear	PA (Black)
4	Spring	C5191
5	Base	PA (Brown)
6	Terminal	C5210
7	Base (Switch)	PA (Brown)
8	Terminal (Switch)	C5210
9	Spring (Switch)	SUS

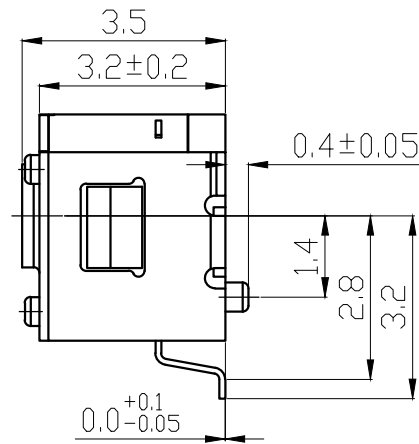

CW ROTATION
 Click

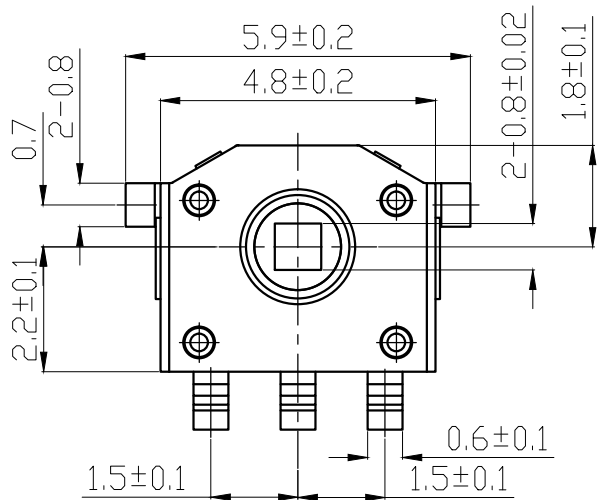
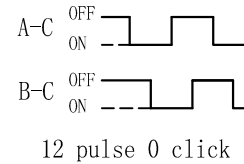

Rating	5VDC 0.5mA
Contact Resistance	500mΩ Max
Insulation Resistance	10MΩ Min
Dielectric Voltage	50VAC 60±5S
Endurance (Encoder)	100,000 cycles
Rotational Force	0-8 gf.cm
Endurance (Switch)	100,000 cycles
Switch travel	0.15±0.05mm
Push switch force	200±50gf

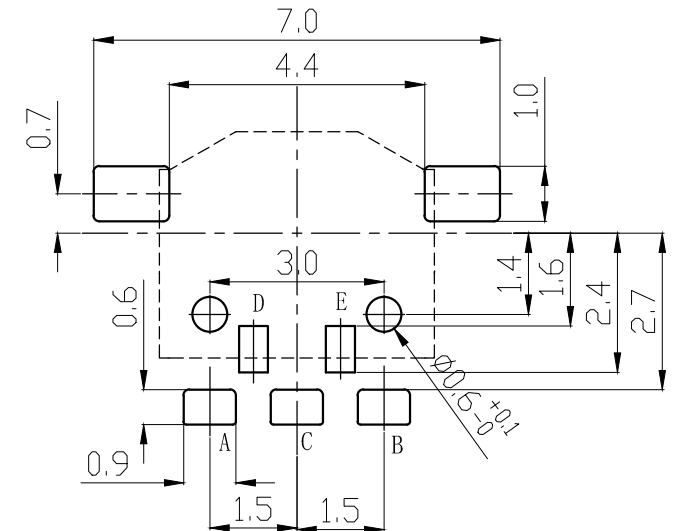
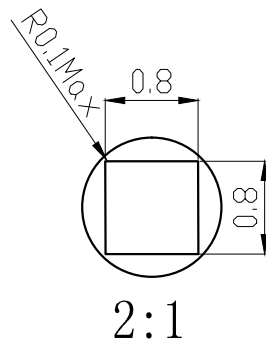
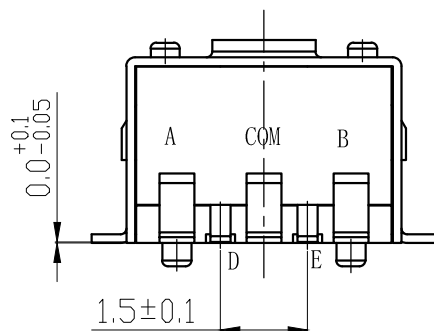

(Tolerance: ±0.1)
 (P.C.B thickness t=0.3~0.5)